



Project:
Item Number:
Quantity:

HIGH POWER 4-SERIES COUNTERTOP INDUCTION RANGES WITH TEMPERATURE CONTROL PROBE



DESCRIPTION

At Vollrath, the best keep getting better. Our next generation induction ranges improve upon the features you have come to rely on — powerful heating, temperature control, efficiency, reliability and usability.

Redesigned inside and out. Industry-setting performance with patented power control, precise temperature and power levels, four customizable programs and a temperature control probe. Easy to use touch screen and a patented, sleek new design.

Use for simmering sauces, stocks and deep frying.

Designed to work with a wide range of induction-ready cookware, but optimized to perform with Vollrath induction-ready cookware. See the Operator's Manual for details.

WARRANTY

2 year warranty. See Vollrath.com for full warranty details.

ACCESSORIES

- 59951 USB mini drive with program editor
- 59952 Temperature control probe with pan clip
- 59953 Pan clip only

AGENCY LISTINGS



This device complies with Part 18 of the FCC Rules.

Certified to NSF4

Due to continued product improvement, please consult www.vollrath.com for current product specifications.

ITEMS

Item No.	Description
HPI4-2600	Countertop induction range with temperature control probe and programs, 2600 watts
HPI4-3000	Countertop induction range with temperature control probe and programs, 3000 watts
HPI4-3800	Countertop induction range with temperature control probe and programs, 3800 watts

FEATURES

- Expanded magnetic field emulates gas to allow uninterrupted heat while lifting or tilting pan to sauté or flip.
- Smarter, faster pan detection technology delivers uninterrupted heat when lifting a pan to flip, saute or add ingredients.
- Patented circuitry delivers steady heat. No power cycling.
- Control knob is fast and precise. A quick spin brings food to a boil or reduces it to a simmer; or dial in a precise temperature or power level.
- Power level control offers responsive gas flame-like control, in increments from 1 to 100% of watts. Use for fast, powerful heating.
- Temperature control is the most accurate in the industry, providing steady, controlled heating in single degree increments in °F (80-450°) and °C (27-232°). Use for more precise pan temperature.
- Included Temperature Control Probe provides additional temperature accuracy. Heats food to a selected temperature, then monitors the food and adjusts the power output to maintain the selected temperature. Use it to heat stocks and sauces to a selected temperature and simmer for hours without boil overs. Not for use as a thermometer.
- Four customizable programs delivery repeatable results with the touch of a button. Each program can have up to three stages that set temperature or power level and optional timer. Programmed cooking increases kitchen efficiency by reducing operator error and waste.
- Time to boil is 28% faster than gas and up to 19% faster than competitive induction ranges.
- 93% efficiency rating is the highest in the industry which means more heat transmitted to the pan and less to the kitchen.
- Touch screen control panel.
- Timer with audible alarm. Heating stops when time expires.
- Power monitoring technology senses and compensates for fluctuations in supply voltages that can occur in busy kitchens to deliver consistent performance and repeatable results during slow and peak cooking times.
- Internal cooling system provides reliability and durability; and is easy to maintain – no filters to remove or clean,
- Stainless steel case with glass cooking surface.
- 6 ft. (183 cm) power cord with plug.
- 22 in. (56 cm) temperature control probe cord.

Approvals	Date



The Vollrath Company, L.L.C.

1236 North 18th Street
Sheboygan, WI 53081-3201 U.S.A.
Main Tel: 800.624.2051 or 920.457.4851
Main Fax: 800.752.5620 or 920.459.6573
Customer Service: 800.628.0830

Technical Services

techservicereps@vollrathco.com
Induction Products: 800.825.6036
Countertop Warming Products: 800.354.1970
All Other Products: 800.628.0832

HIGH POWER 4-SERIES COUNTERTOP INDUCTION RANGES WITH TEMPERATURE CONTROL

DIMENSIONS (Shown in inches (cm))

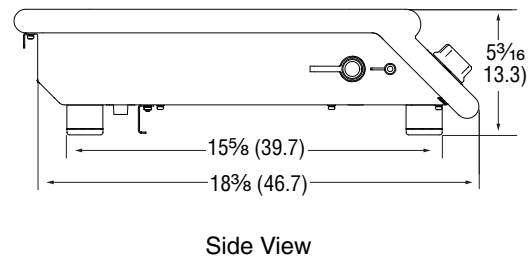
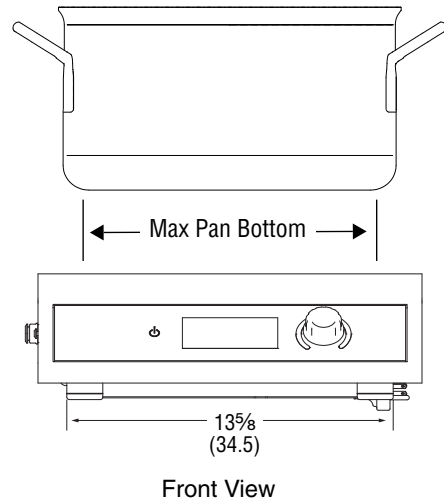
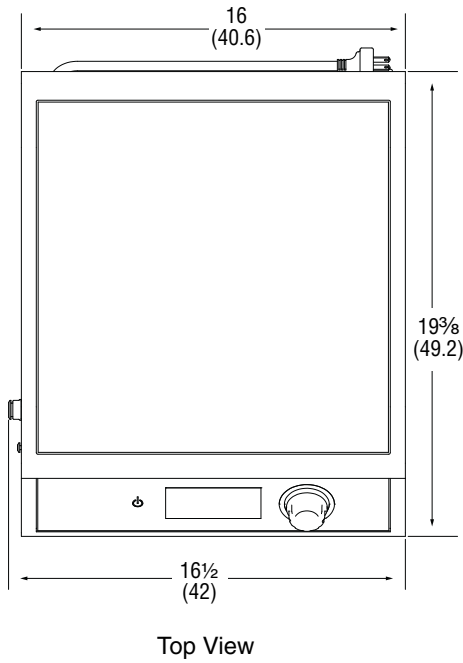

CLEARANCE AND ENVIRONMENT REQUIREMENTS

- Indoor use only.
- Minimum required clearance for a single range is 2 inches (5.1 cm) in the front and 2 inches (5.1 cm) in the back. Requirements change when using ranges adjacent to each other. Refer to the Operator's Manual for details.
- All models require unrestricted intake and exhaust air ventilation for proper operation of the controls.
- Maximum Ambient Temperature as measured at the air intake is 104°F (40°C) while all appliances in the kitchen are in operation.
- This equipment requires a dedicated circuit.

SPECIFICATIONS

Item No.	Maximum Pan Bottom Diameter* In (CM)	Voltage	Watts	Amps	Hz	Plug
HP14-2600	14 (35.6)	208-240	2600	10.8	50/60	NEMA 6-20P
HP14-3000			3000	12.5		
HP14-3800			3800	15.8		

Receptacle

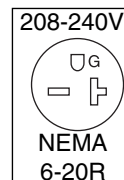

* Maximum pan diameter is provided as a guideline for achieving maximum performance. Cookware with a larger base diameter can be used, however only the area of the cookware above the induction coil will heat. The more cookware extends past the coil, the more the overall performance will be reduced. Other factors impact performance including pan construction, material, the density and volume of the food in the pan, ambient temperature and food temperature. Cookware with inferior construction or material may not perform well.



www.vollrath.com

The Vollrath Company, L.L.C.

1236 North 18th Street
 Sheboygan, WI 53081-3201 U.S.A.
 Main Tel: 800.624.2051 or 920.457.4851
 Main Fax: 800.752.5620 or 920.459.6573
 Customer Service: 800.628.0830
 Canada Customer Service: 800.695.8560

Technical Services

techservicereps@vollrathco.com
 Induction Products: 800.825.6036
 Countertop Warming Products: 800.354.1970
 All Other Products: 800.628.0832