



Outperform every day.™

Project:
Item Number:
Quantity:

HEAVY-DUTY ELECTRIC SLICER



Heavy-Duty Electric Slicer

DESCRIPTION

The Vollrath Heavy-Duty Electric Slicer is ideal for slicing meats and cheeses in higher-volume operations such as large restaurants.

Agency Listings



Certified to NSF/ANSI 8

Due to continued product improvement, please consult www.vollrath.com for current product specifications.

ITEMS

Item No.	Model No.	Description
40952	SLP300/S	12" Heavy-Duty Slicer, 35°

FEATURES

- 1/2 peak HP heavy-duty motor for continuous use and higher torque for cheese slicing
- Expanded 1" (2.5 cm) slice thickness
- QuanTanium® coated non-stick plate with titanium blended into the coating creates a harder and more durable surface than conventionally reinforced systems
- Non-stick plate increases glide performance and reduces clean-up time
- Built-in sharpener
- 35 degree gravity feed maximizes productivity by reducing operator fatigue and discomfort
- Safety hand guard mounted to carriage
- Safety cover under motor
- Hard coated anodized aluminum body
- Non-marking, non-skid rubber feet
- Belt driven. Durable, long-wearing belt provides reliable service.
- Solid aluminum slice adjustment knob for precise and consistent slice thickness
- Removable carriage for easy cleaning
- Large receiving tray
- Safe blade Removal System
- Permanent blade rim guard for safety
- 6'4" (1.9 m) cord with plug

ACCESSORIES

- 40896 - 12" serrated blade
- 40895 - 7" stainless steel vegetable chute with pusher
- 40893 - 12" safe blade removal tool
- 40899 - Carriage handle for Quebec

Warranty

1 year on parts, 1 year on labor and 5 years on the belt. See Vollrath.com for full warranty details.

Approvals	Date



The Vollrath Company, L.L.C.
1236 North 18th Street
Sheboygan, WI 53081-3201 U.S.A.
Main Tel: 800.624.2051 or 920.457.4851
Main Fax: 800.752.5620 or 920.459.6573

Technical Services
techservicereps@vollrathco.com
Induction Products: 800.825.6036
Countertop Warming Products:
800.354.1970

HEAVY-DUTY ELECTRIC SLICER

DIMENSIONS (Shown in inches (cm))

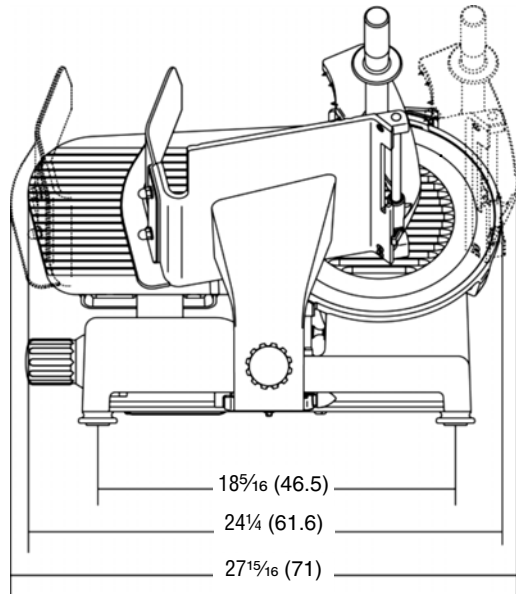

Side View

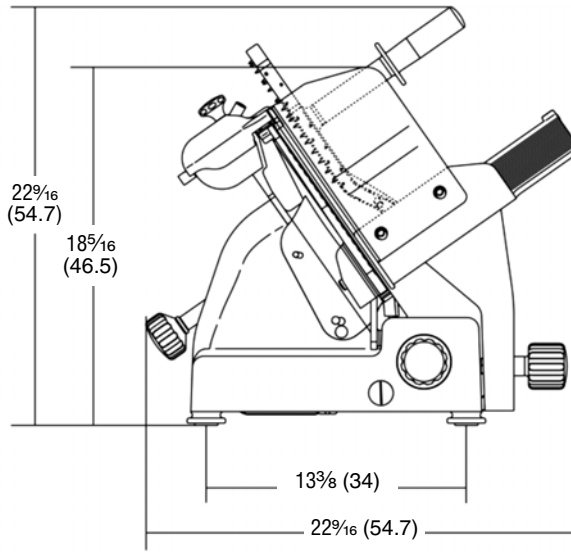

Front View

SPECIFICATIONS

Item No.	Description	Peak HP	Voltage	Amps	Hertz	Weight Lbs (Kg)	Plug
40952	12" Heavy-Duty Slicer, 35°	1/2	120	2	60	77 (35)	NEMA 5-15P

Receptacle

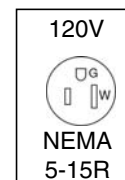

Outperform every day.™

www.vollrath.com

The Vollrath Company, L.L.C.
 1236 North 18th Street
 Sheboygan, WI 53081-3201 U.S.A.
 Main Tel: 800.624.2051 or 920.457.4851
 Main Fax: 800.752.5620 or 920.459.6573
 Customer Service: 800.628.0830

Technical Services
techservicereps@vollrathco.com
 Induction Products: 800.825.6036
 Countertop Warming Products:
 800.354.1970
 All Other Products: 800.628.0832