



XAVL-2021-NPRS

Project _____

Item _____

Quantity _____

Date _____

Model
**CHEFTOP MIND.Maps™ PLUS
 BIG**

- Combi steamer
- Gas
- 20 trays GN 2/1
- Hinge on the left side (Right hand door)
- 9.5" Touch control panel
- 20 trays 18"x26"



DESCRIPTION

Technologically advanced combi oven for gastronomy cooking processes (dehydrating, steaming, low temperature cooking, sous vide cooking, roasting, grilling, pan frying, regeneration and plate regeneration) and for fresh or frozen baking thanks to Unox Intensive Cooking and Intelligence Performance technologies which guarantee perfect results and repeatability for any load size. Automatic management of cooking processes (CHEFUNOX) for perfect results even without trained staff.

STANDARD COOKING FEATURES

Programs

- 1000+ Programs
- **CHEFUNOX**: choose something to cook from the library and the oven will automatically set all the parameters
- **MULTI.TIME**: manages up to 10 cooking processes at the same time
- **MISE.EN.PLACE**: synchronises the insertion of pans so that all the dishes are ready at the same time
- **MIND.Maps™**: draw the cooking processes directly on the display
- **READY.COOK**: ready to use settings with infinite time for a quick start

Manual cooking

- **Temperature**: 86 °F – 500 °F
- Up to 9 cooking steps
- **CLIMA.Control**: humidity or dry air set by 10%
- Delta T cooking with core probe
- SOUS-VIDE cooking
- 4-speed fan system

STANDARD TECHNICAL FEATURES

- **ROTOR.Klean™**: automatic washing system
- Automatic special washing behind the fan guard
- Cooking chamber in high-resistance AISI 304 stainless steel with rounded edges
- Triple glass
- Cooking chamber lighting through LED lights embedded in the door
- Tray supports with anti-tip system
- Drip collection system integrated in the door which works even when the door is open
- 4-speed fan system and high-performance heating elements
- Integrated DET&Rinse™ detergent container
- Integrated Wi-Fi
- **Wi-Fi / USB data**: download/upload HACCP data
- **Wi-Fi / USB data**: download/upload programs
- Fully integrated drain cooling valve (drain discharge temp. ≤ 140°F)

ADVANCED AND AUTOMATIC COOKING FEATURES

Data Driven Cooking

- Control and monitor the operating conditions of your ovens in real-time, create and share new recipes. The AI transforms the consumption data into useful information in order to increase your daily profit. Create, understand, improve

Unox Intelligent Performance

- **ADAPTIVE.Cooking™**: automatically regulates the cooking parameters to ensure repeatable results
- **CLIMALUX™**: total control of the humidity in the cooking chamber
- **SMART.Preheating**: automatically sets the preheating temperature and duration
- **AUTO.Soft**: manages the heat rise to make it more delicate
- **SENSE.Klean**: estimates how dirty the oven is and suggests the appropriate automatic washing cycle

Unox Intensive Cooking

- **DRY.Maxi™**: rapidly extracts the humidity from the cooking chamber
- **STEAM.Maxi™**: produces saturated steam
- **AIR.Maxi™**: manage fans auto-reverse and pulse function
- **PRESSURE.Steam**: increases the steam saturation and temperature

APP & WEB SERVICES

- Data Driven Cooking app & webapp
- Top Training app
- Combi guru app



We reserve the right to make technical improvements - 03/25/2022

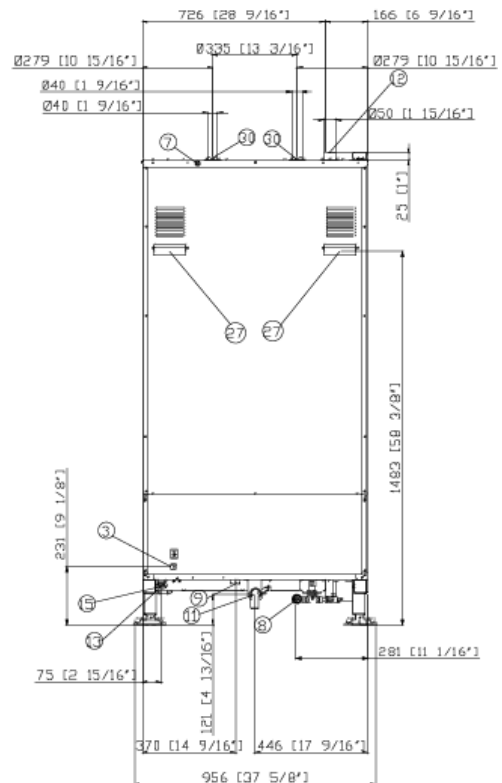
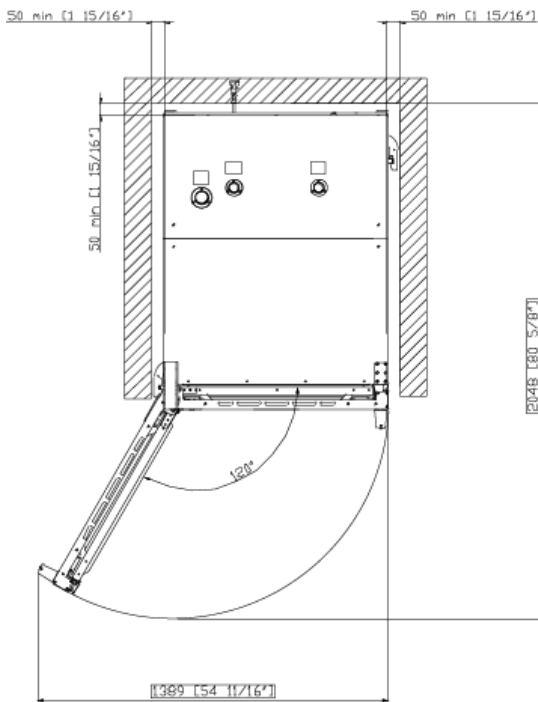
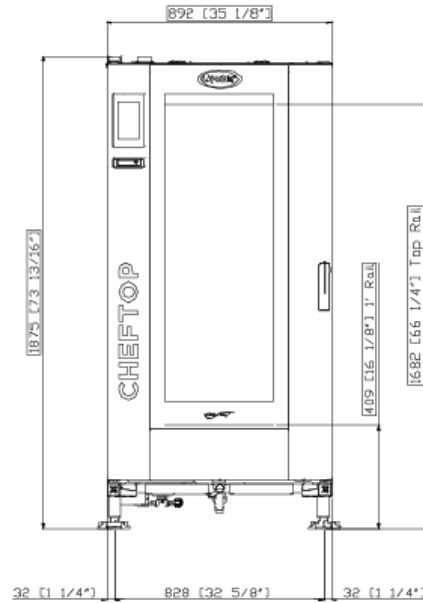
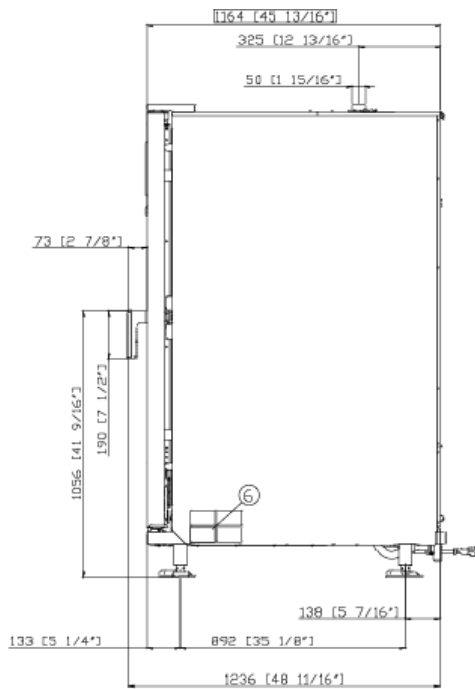

DIMENSIONS AND WEIGHT

Width	35-1/8"	892 mm
Depth	45-53/64"	1164 mm
Height	73-7/8"	1875 mm
Net Weight	778 lbs	370 kg
Tray pitch	2-11/16"	67 mm

CONNECTION POSITIONS

2	Terminal board power supply	11	Chamber drain pipe
3	Unipotential terminal	12	Hot fumes exhaust chimney
7	Safety thermostat	13	Accessories connection
8	3/4" Thread water inlet	6	Technical data plate
9	1" Gas inlet	27	Cooling air outlet
10	Rotor:KLEAN™ inlet	30	Combustion gasses exhaust



XAVL-2021-NPRS

Power and gas supply
 Water connections
 Installation requirements
 Accessories

POWER AND GAS SUPPLY

STANDARD	
Voltage	208-240 V
Phase	~1PH+PE
Frequency	60 Hz
Total power	2.6 kW
Maximum Amp Draw	11 A
Required breaker size	20 A
Power cable requirements*	3 x AWG 14
Plug	NEMA 6-20P

*Recommended size - observe local ordinance

GAS

Gas type	NG	LPG
Nominal gas power	307093 BTU/h	307093 BTU/h
Inlet pressure	Min. 3.5 i.w.c. Max 10.5 i.w.c.	Min. 8.0 i.w.c. Max 13.0 i.w.c.
Gas valve orifice	-	2-11/64"
Gas hook-up	1" NPT	1" NPT

WATER SUPPLY

USING A WATER SUPPLY THAT DOES NOT MEET UNOX'S MINIMUM WATER QUALITY STANDARDS WILL VOID ANY WARRANTY.

It is the responsibility of the purchaser to ensure that the incoming water supply is compliant with the listed specifications through adequate treatment measures.

Line pressure: Drinking water inlet: 3/4" NPT*, line pressure: 22 to 87 psi; 1.5 to 6 Bar (29 psi; 2 Bar recommended)

Inflow water specifications

Free chlorine	≤ 0.5 ppm
Chloramine	≤ 0.1 ppm
pH	7 - 8.5
Electrical conductivity	≤ 1000 µS/cm
Total hardness	≤ 30 °dH

Steam circuit: inflow water specifications

Total hardness	≤ 8 °dH*
Chlorides	≤ 250 ppm

*this value refers to daily steam cooking of 1- 2 hours. In any case, if with a total hardness ≤ 8°dH there is still production of limescale, it is mandatory to treat the water in order to avoid limescale production. We recommend water treatment systems based on ion exchange resins. Water treatment systems based on polyphosphates are not allowed.

ACCESSORIES

- QUICK.Load and trolley system
- Cooking Essentials: special trays
- Sous-vide core probe
- DET&Rinse™ PLUS: cleaning and rinse agents to combine maximum cleanliness with minimum consumption and long life for your oven
- DET&Rinse™ ECO: eco formula for daily cleaning and the utmost respect for the environment. Ideal for mild level of dirt.
- DET&Rinse™ ULTRA: cleaning and rinse agents to combine maximum cleanliness with minimum consumption and long life for your oven
- Finest: resin-based filtering system that eliminates from the water all substances that contribute to the formation of limescale inside the oven cooking chamber
- Ethernet connection kit

INSTALLATION REQUIREMENTS

Installations must comply with all local electrical systems, particularly as for minimum wire gauge required for field connection, hydraulic and ventilation supply. Exhaust and fume analysis must be performed in case of gas ovens.

Register to access data and product specifications
www.ddc.unox.com