



Job \_\_\_\_\_ Item No. \_\_\_\_\_

# Star® Electric Quartz Heater Conveyor Ovens - Analog Controls

□210HX □214HX □314HX



210HX



314HX Double Stacked

## DESCRIPTION

Star's Mini & Proveyor® ovens are designed to cook a variety of menu items such as fresh dough pizza, blanched pizza, subs, cookies, fish and more quickly and easily while preserving cooking space. Quartz infrared heaters provide faster, more consistent heating than traditional heating elements. Elements are located above and below conveyor belt allowing precise even heating of products.

## SPECIFICATIONS

Ovens are constructed of stainless steel. Conveyor belt travels left to right. Single and stacked ovens furnished with 2-1/2" adjustable legs, quartz infrared heat-ers and on/off heat switch for heat control are standard. Product opening adjustable from 1-1/2" to 3", motors are permanently lubricated and bearings are long lasting teflon. Units are UL listed, CSA certified and NSF approved.

## WARRANTY

These units come with a one [1] year warranty for parts and labor.

## FEATURES

- High-power quartz infrared elements are located above and below conveyor belt allowing precise even heating of products
- Convection system keeps the conveyor cool-to-the-touch and extends the life of critical components. The forced convection increases productivity by circulating preheated air into the toasting chamber
- Analog controls for conveyor belt speed , top and bottom heat
- Compact design can be stacked two (2) high (210HX & 214HX), or three (3) high 314HX with optional stacking kit
- Product entry and exit openings are adjustable from 1-1/2" to 3" (210HX & 214HX). 314HX is adjustable from 1-1/2" to 4"
- Removable 6-1/2" long extended load/unload area standard
- Removable crumb tray for fast and easy clean-up

BAKING CAPACITY	
MODEL	CAPACITY
210HX (120V)	APPROXIMATELY 30-6" PIZZAS/HR, 26-9" PIZZAS/HR (BLANCHED SHELL)
210HX (208/240V)	APPROXIMATELY 45-6" PIZZAS/HR, 31-9" PIZZAS/HR (BLANCHED SHELL)
214HX (208/240V)	APPROXIMATELY 31-9" PIZZAS/HR, 14-12" PIZZAS/HR (BLANCHED SHELL)
314HX	APPROXIMATELY 14-16 12" PIZZAS/HR, 56-60 5" PIZZAS/HR (FRESH DOUGH)

## OPTIONS & ACCESSORIES

- SSK-210HX - 210HX Stacking Kit
- SSK-214HX - 214HX Stacking Kit
- SSK-314HX - 314HX Stacking Kit

## CERTIFICATIONS



### STAR MANUFACTURING INTERNATIONAL INC.

265 Hobson St. • Smithville, Tennessee 37166  
Telephone 800 264 7827 • Fax 314 781 5445  
www.star-mfg.com

Printed in the U.S.A. • 2M-Z22865 • Rev A • 11.2018  
Specifications are subject to change without notice  
and are not intended for installation purposes.



# Star® Electric Quartz Heater Conveyor Ovens - Analog Controls

□210HX □214HX □314HX

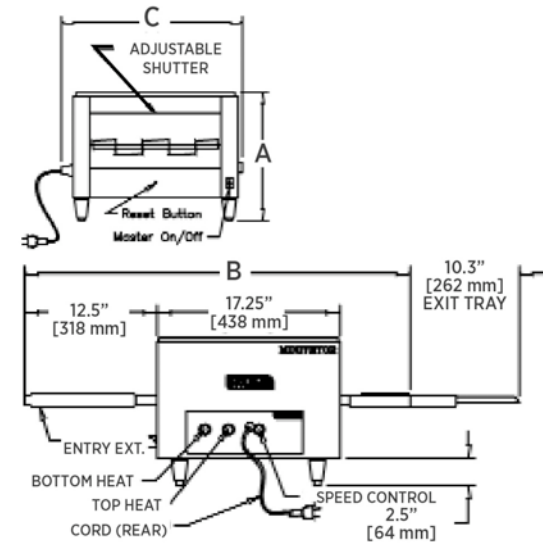

### CLEARANCES

Ovens must have a 6" clearance from ends to any combustible material.

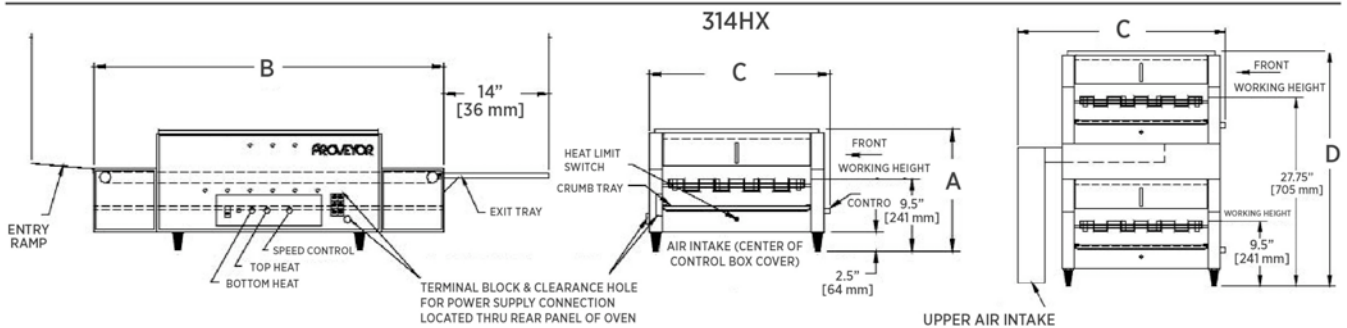
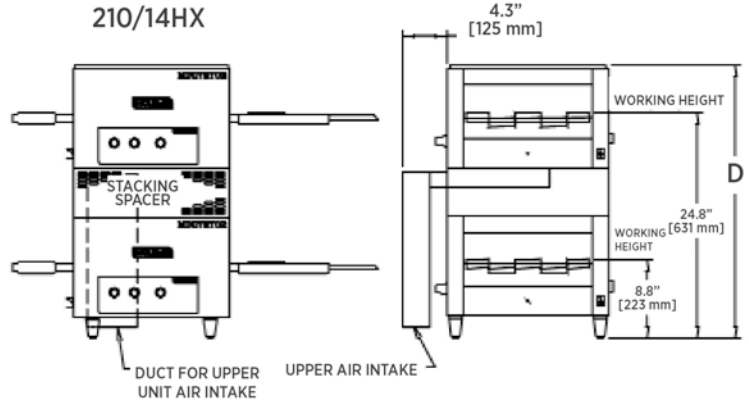

MODEL	OVEN DIMS - SINGLE UNITS			DOUBLE STACKED OVEN DIMS			BELT DIMS		COOKING CHAMBER DIMS	
	HEIGHT [A] in. (mm)	WIDTH [B] in. (mm)	DEPTH [C] in. (mm)	HEIGHT [A] in. (mm)	WIDTH [B] in. (mm)	DEPTH [D] in. (mm)	BELT WIDTH in. (mm)	BELT LENGTH in. (mm)	WIDTH in. (mm)	LENGTH in. (mm)
210HX	14.0 (356)	36.4 (925)	15.4 (392)	30.1 (765)	36.4 (925)	20.3 (516)	10.0 (254)	31.0 (787)	10.3 (262)	16.9 (429)
214HX	14.0 (356)	36.4 (925)	19.4 (493)	30.1 (765)	36.4 (925)	24.3 (617)	14.0 (356)	31.0 (787)	14.3 (363)	16.9 (429)
314HX	16.1 (409)	38.7 (983)	21.3 (541)	34.0 (864)	38.7 (983)	27.0 (686)	14.0 (356)	38.0 (965)	16.0 (406)	21.5 (546)
MODEL	HZ*	VOLTS1	AMPS	WATTS	NEMA PLUG		APPROX. SHIP WEIGHT		APPROX. INSTALLED WEIGHT	
210HX	60	120	14.2	1,700	6-20P	5-15P 5-20P* 6-20P 5-20P	60 lb. (28 kg)	38 lb. (18 kg)		
		120	14.2	1,700						
		208	13.5	2,800						
		240	11.7	2,800						
214HX	60	208	19.3	4,000	6-30P 6-30P* N/A N/A	6-30P	66 lb. (31 kg)	43 lb. (20 kg)		
		240	16.7	4,000						
		220	18.2	4,000						
		240	16.7	4,000						
314HX	60	208	26.4	5,400	6-50P	6-50P	115 lb. (52 kg)	86 lb. (40 kg)		

1Specify 120, 208V, 240V or 220V service when ordering. All units rated for 50-60Hz cycles.

\*Canadian Requirements

Electric Conveyor ovens can be stacked two (2) high

Due to periodic changes in designs, methods, procedures, policies and regulations, the specifications contained in this sheet are subject to change without notice. While Star Manufacturing exercises good faith efforts to provide information that is accurate, we are not responsible for errors or omissions in information provided or conclusions reached as a result of using the specifications. By using the information provided, the user assumes all risks in connection with such use.



### STAR MANUFACTURING INTERNATIONAL INC.

265 Hobson St. • Smithville, Tennessee 37166  
Telephone 800 264 7827 • Fax 314 781 5445  
www.star-mfg.com

Printed in the U.S.A. • 2M-Z22865 • Rev A • 11.2018  
Specifications are subject to change without notice  
and are not intended for installation purposes.