



NE-1024

1000 Watt* Commercial Microwave Oven

- Stainless Steel Front
- 1000* Watts of Power
- Capacity: 0.8 cubic feet
- “Grab & Go” Door Handle
- Bottom Energy Feed
- 6 Minute Dial Timer
- Chef Technical Support
- Fits One Half-size 6"-Tall Pan with Cover
- Interior Oven Light
- See-Through Oven Door
- Anti-Theft Equipped
- Will Ship via UPS

Technical Specifications

Power source: 120V, 60Hz, Single phase

Receptacle required: NEMA 5-15 R or
NEMA 5-20 R



Frequency: 2,450MHz

Required power: 13.4A

Output: 1000 watts*

Outer dimensions: 20 $\frac{1}{8}$ " w x 16 $\frac{1}{16}$ " d x 12" h

Cavity dimensions: 13" w x 13" d x 8 $\frac{1}{16}$ " h

Net weight: 34 lbs.

Shipping weight: 39 lbs.

Shipping box size: 24" w x 18 $\frac{3}{4}$ " d x 14 $\frac{3}{4}$ " h, 3.8 cu. ft.

Timer: 6 Minute Dial

To specify a Panasonic Commercial Microwave Oven

The NE-1024 Commercial Microwave Oven meets or exceeds all safety performance and sanitation standards set for commercial food service microwave ovens by UL, DHHS, FCC and NSF.

Plus, oven shall have output power 1000 Watts*, stainless steel front and bottom energy feed. Must be equipped with 6 minute dial timer marked in 15 second increments, instructions and cooking times visible on oven control panel, interior oven lamp, see-through window, door safety lock system, Chef/Test Kitchen technical support and 3 year limited warranty.

**I.E.C. 60705 Test Procedure. Specifications subject to change without notice.*

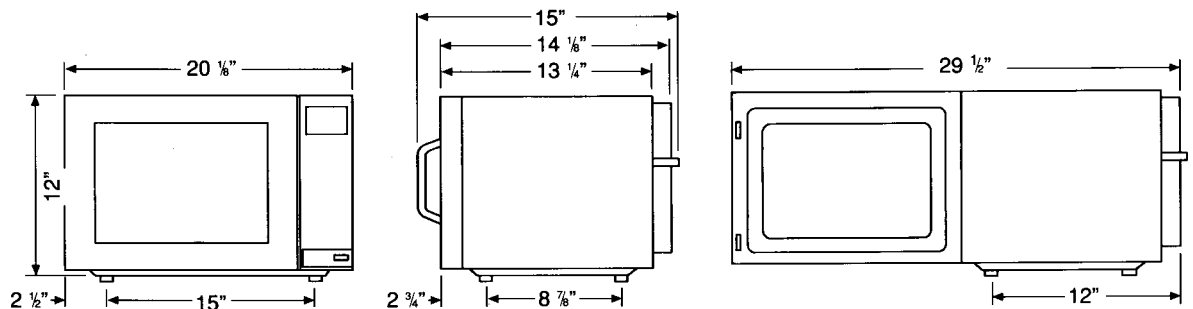

Panasonic

Panasonic Appliance & Commercial Group

Division of Matsushita Electric Corporation of America

Executive Offices:

One Panasonic Way, Panazip 4A-1, Secaucus, NJ 07094