



Project \_\_\_\_\_  
 AIA # \_\_\_\_\_ SIS # \_\_\_\_\_  
 Item # \_\_\_\_\_ Quantity \_\_\_\_\_ C.S.I. Section 114000



## HL800 LEGACY+ 80-Quart Maximum Heavy-Duty Mixer



### SPECIFIER STATEMENT

Specified mixer will be an NSF rated 80-quart maximum heavy-duty, all-purpose mixer with Hobart PLUS System, four fixed speeds plus a stir speed. Mixer has 3 HP output at the planetary shaft and gear transmission. Features include automatic time recall, swing-out bowl, Shift-on-the-Fly™ controls and power bowl lift. Mixer finished with a metallic gray hybrid powder coat and has a stainless steel bowl guard.

### MODEL

- HL800** 80-Quart Maximum Heavy-Duty Mixer
- HL800C** 80-Quart Maximum Heavy-Duty Mixer with Maximum Security Correctional Package

### STANDARD FEATURES

Features in bold are exclusive to Hobart

- + **PLUS System**
  - **VFDadvantage** variable frequency drive
  - **Maximum capacity** overheat protection
  - **Reinforced planetary shaft system**
- + **Triple interlock system with MagnaLock technology**
- + Heavy-duty 3 HP motor
- + Gear transmission
- + Four fixed speeds, plus stir speed
- + **Shift-on-the-Fly™ controls**
- + Soft start agitation technology
- + **20-minute SmartTimer™**
- + Automatic time recall
- + Large, easy-to-reach controls
- + **Single point bowl installation**
- + **Ergonomic swing-out bowl**
- + Power bowl lift
- + Open base
- + Metallic gray hybrid powder coat finish
- + Stainless steel removable bowl guard
- + FastStop

### ACCESSORY PACKAGE

Featuring Hobart Quick Release™ Agitators

- HL800-1STD Standard Accessory Package includes:
  - + 80-quart stainless steel bowl
  - + 80-quart “B” beater
  - + 80-quart “ED” dough hook
  - + 80-quart bowl truck

HL800 LEGACY+ 80-QUART MAXIMUM HEAVY-DUTY MIXER

Approved by \_\_\_\_\_ Date \_\_\_\_\_ Approved by \_\_\_\_\_ Date \_\_\_\_\_



# HL800 LEGACY+ 80-Quart Maximum Heavy-Duty Mixer

## SOLUTIONS/BENEFITS

### PERFORMANCE

#### VFD*advantage* Variable Frequency Drive

- + Direct drive system
- + Ensures superior mixing consistency, motor protection and long life

#### Quick Release™ Agitators

- + Eliminates the up/down play of bayonet-style agitators
- + Consistent agitator-to-bowl ratio delivers superior mixing performance

#### Five Mixing Speeds

- + Can handle virtually any mixing job
- + Includes stir speed

#### Reinforced Planetary Shaft System

- + Rugged durability under the most challenging mixing conditions

### EASE OF USE

#### Ergonomic Swing-Out Bowl

- + Easily swing bowl to the side to remove/add ingredients
- + Adds convenience and saves time

#### Single-Point Bowl Installation

- + Easy-to-mount bowl uses only one point to install
- + Reduces risk of spills, speeds up mixing process

#### Power Bowl Lift

- + Electronic, smoothly moves bowl into mixing position

#### Shift-on-the-Fly™ Controls

- + Allows safe, convenient speed changes while the motor is running
- + Pulse and jog as needed

#### 20-Minute SmartTimer™

- + Automatic recall of time and speed

### SANITATION & CLEANING

#### Stainless Steel Removable Bowl Guard

- + Easy to remove without tools for cleaning
- + Dishwasher-safe for easy cleaning and sanitizing

#### Soft Start Agitation Technology

- + Gradually delivers electricity to the mixer
- + Minimizes the risk of ingredient splash out

### OPERATOR ASSURANCE

#### Triple Interlock System with MagnaLock Technology

- + Prevents mixer from operating unless the bowl is fully up and locked in place and the bowl guard is secured

#### FastStop

- + VFD*advantage* brings all moving parts to a complete stop in less than 3 seconds

## HL800 MIXER CAPACITY CHART

Recommended Maximum Capacities – dough capacities based on 70°F water and 12% flour moisture.

Product	Agitators Suitable for Operation	HL800
Capacity of Bowl (Qt. Liquid)		80
Egg Whites	D	2 qt.
Mashed Potatoes	B & C	60 lb.
Whipped Cream	D or C	16 qt.
Cakes	B	100 lb.
Cookies, Sugar	B	60 lb.
Dough, Bread or Roll ★ (Lt.-Med.) 60% AR	ED	170 lb. ▲
Dough, Heavy Bread 55% AR ★	ED	140 lb. ▲
Dough, Thin Pizza 40% AR ★ (max. mix time 5 min.)	ED	85 lb. ●
Dough, Thick Pizza 60% AR ★	ED	155 lb. ■
Dough, Whole Wheat 70% AR	ED	150 lb. ■
Icing, Fondant	B	65 lb.
Icing, Marshmallow	C or I	10 lb.
Pasta, Basic Egg Noodle (max. mix time 5 min.)	ED	65 lb. ●

**Note:** % AR (% Absorption Ratio) – Water weight divided by flour weight. Capacity depends on moisture content of dough. Above capacities based on 12% flour moisture at 70°F water temperature.

● 1st Speed

■ 2nd Speed

▲ 3rd Speed

★ If high gluten flour is used, reduce above dough batch size by 10%.

2nd speed should never be used on 50% AR or lower products.

Use of ice requires a 10% reduction in batch size.

1 gallon of water weighs 8.33 lbs.



# HL800 LEGACY+ 80-Quart Maximum Heavy-Duty Mixer

## SPECIFICATIONS

**Motor:** 3 HP high torque motor.

200-240/50/60/3 – 12.0 Amps

380-460/50/60/3 – 6.0 Amps

**Electrical:** 200-240/50/60/3, 380-460/50/60/3 – UL Listed.

**Controls:** Magnetic contactor and thermal overload protection. Internally sealed “Start-Stop” and Power Bowl Lift push buttons. Reduced voltage pilot circuit transformer is supplied for 380-460/50/60/3 machines. A 20-minute SmartTimer™ is standard. SmartTimer™ includes:

- **Automatic Time Recall**, which remembers the last time set for each speed.
- **Transmission:** A rated 10 HP poly-V belt transfers power from motor to input shaft then geared down to desired reduction with a constant gear mesh. Gears and shafts are heat-treated hardened alloy steel along with anti-friction ball bearings. Circulating oil and grease lubricants furnished to all gears and shafts.

Speeds	Agitator (RPM)
Stir	27
First	55
Second	96
Third	183
Fourth	322

**Bowl Guard:** Heavy-duty stainless steel wire front and solid rear portion. Front portion of guard rotates easily to add ingredients and install or remove agitator. It detaches in seconds for cleaning in dishwasher or sink. Rear portion of guard can be quickly cleaned in position. Guard must be in closed position before mixer will operate. Bowl support interlock provides further protection.

**Power Bowl Lift:** Powered by an electric motor, the bowl may be raised or lowered by fingertip control through the conveniently located switch. Bowl will remain in position until switch is activated.

**Stir-on-Lift Feature:** Allows the agitator to run in Stir Speed while the mixer bowl is being raised. Once the bowl is in the raised position, the mixer automatically shifts into the preselected speed.

**Warranty:** Unit has full one-year warranty on parts, labor and mileage against manufacturer’s defects. Service contracts are available.

**Finish:** Metallic gray hybrid powder coat finish.

**Footpads:** Neoprene footpads are standard.

## Attachments and Accessories:

The following are available at extra cost:

Attachment / Accessory	Device #
Stainless Steel Bowl	BOWL-HL80
“B” Flat Beater	BBEATER-HL80
“C” Wing Whip	CWHIP-HL80
“D” Wire Whip	DWHIP-HL80
“ED” Dough Hook	EDDOUGH-HL80
“P” Pastry Knife	PPASTRY-HL80
“I” Heavy Duty Wire Whip	IWIRE-HL80
Bowl Splash Cover (lexan)	SPLASH-LEX080
Bowl Scraper	SCRAPER-HL80
Ingredient Chute	CHUTE-LMV
Bowl Truck	TRUCK-HL1486
Bowl Extension Ring	EXTEND-SST80G
40 Quart Accessories	See HL400 spec sheet
60 Quart Accessories	See HL600 spec sheet

## Plugs and Receptacles:

Dependent on local power codes; cords not provided

	Machine Voltages	
	HL800	380-460
<b>Service Current Requirement if Plug Connected</b>	230/60/3	460/60/3
	20 Amp.	20 Amp.
<b>Terminal Designation of Plug</b>	3 Pole 4 Wire Grounding	3 Pole 4 Wire Grounding
<b>NEMA Plug Configuration</b>	L15-20P	L16-20P
<b>Plug Configuration</b>		
<b>Molded Plug on Cord</b>	No	No
<b>Plug - Straight/Angle</b>	Straight	Straight
<b>NEMA Receptacle or Connector Configuration</b>	L15-20R	L16-20R
<b>Power Cord Included</b>	No	No



# HL800 LEGACY+ 80-Quart Maximum Heavy-Duty Mixer

## DETAILS AND DIMENSIONS

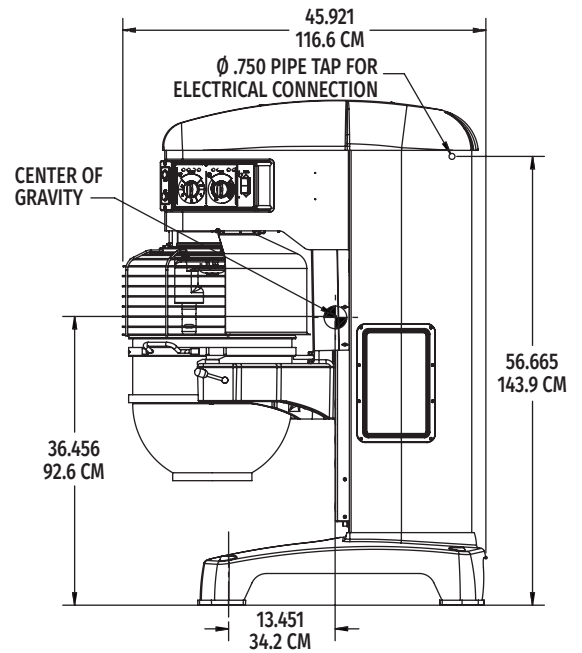
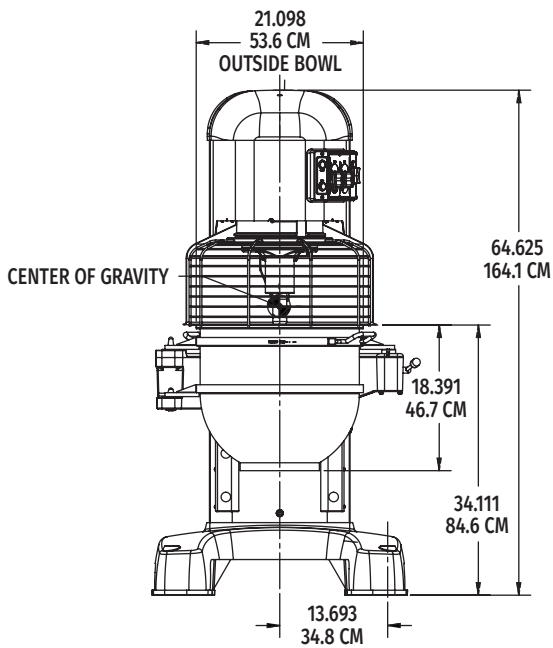
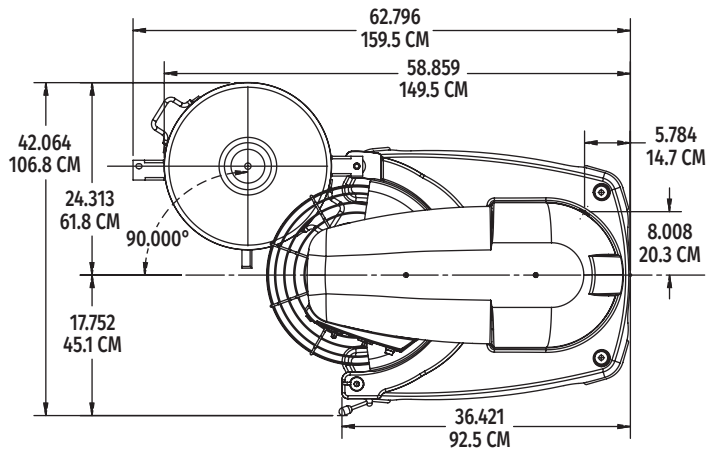
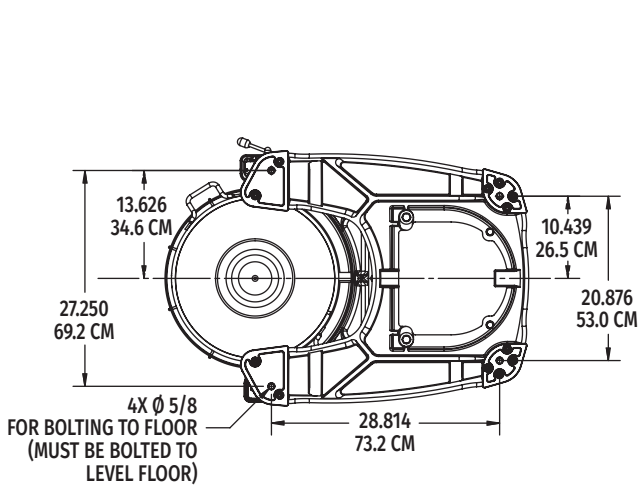

**WARNING:** Electrical and grounding connections must comply with the applicable portions of the National Electrical Code and/or other codes in force.

**NOTE:**  
Standard Model:  
Net Weight (Bowl Included): 1375 lbs. (624 kg)  
Bowl Weight: 55.4 lbs. (25.1 kg) - Ref