



Project _____
 AIA # _____ SIS # _____
 Item # _____ Quantity _____ C.S.I. Section 114000



HL600 LEGACY+ 60-Quart Maximum Heavy-Duty Mixer



SPECIFIER STATEMENT

Specified mixer will be an NSF rated 60-quart maximum heavy-duty, all-purpose mixer with Hobart PLUS System, four fixed speeds plus a stir speed. Mixer has 2.7HP output at the planetary shaft and gear transmission. Features include automatic time recall, swing-out bowl, Shift-on-the-Fly™ controls and power bowl lift. Mixer finished with a metallic gray hybrid powder coat and has a stainless steel bowl guard.

MODEL

- HL600** 60-Quart Maximum Heavy-Duty Mixer
- HL600C** 60-Quart Maximum Heavy-Duty Mixer with Maximum Security Correctional Package

STANDARD FEATURES

Features in bold are exclusive to Hobart

- + **PLUS System**
 - **VFDadvantage** variable frequency drive
 - **Maximum capacity** overheat protection
 - **Reinforced planetary shaft system**
- + **Triple interlock system with MagnaLock technology**
- + Heavy-duty 2.7 HP motor
- + Gear transmission
- + Four fixed speeds, plus stir speed
- + **Shift-on-the-Fly™ controls**
- + Soft start agitation technology
- + **20-minute SmartTimer™**
- + Automatic time recall
- + Large, easy-to-reach controls
- + **Single point bowl installation**
- + **Ergonomic swing-out bowl**
- + Power bowl lift
- + #12 taper attachment hub
- + Open base
- + Metallic gray hybrid powder coat finish
- + Stainless steel removable bowl guard

ACCESSORY PACKAGE

Featuring Hobart Quick Release™ Agitators

- HL600-1STD Standard Accessory Package includes:
 - + 60-quart stainless steel bowl
 - + 60-quart “B” beater
 - + 60-quart “D” wire whip
 - + 60-quart “ED” dough hook

HL600 LEGACY+ 60-QUART MAXIMUM HEAVY-DUTY MIXER

Approved by _____ Date _____ Approved by _____ Date _____



HL600 LEGACY+ 60-Quart Maximum Heavy-Duty Mixer

SOLUTIONS/BENEFITS

PERFORMANCE

VFDadvantage Variable Frequency Drive

- + Direct drive system
- + Ensures superior mixing consistency, motor protection and long life

Quick Release™ Agitators

- + Eliminates the up/down play of bayonet-style agitators
- + Consistent agitator-to-bowl ratio delivers superior mixing performance

Five Mixing Speeds

- + Can handle virtually any mixing job
- + Includes stir speed

Reinforced Planetary Shaft System

- + Rugged durability under the most challenging mixing conditions

Maximum Capacity Overheat Protection

- + Extreme-duty wiring and connections handle more power, reducing thermal cycling impact

EASE OF USE

Ergonomic Swing-Out Bowl

- + Easily swing bowl to the side to remove/add ingredients
- + Adds convenience and saves time

Single-Point Bowl Installation

- + Easy-to-mount bowl uses only one point to install
- + Reduces risk of spills, speeds up mixing process

Power Bowl Lift

- + Electronic, smoothly moves bowl into mixing position

Shift-on-the-Fly™ Controls

- + Allows safe, convenient speed changes while the motor is running
- + Pulse and jog as needed

20-Minute SmartTimer™

- + Automatic recall of time and speed

SANITATION & CLEANING

Stainless Steel Removable Bowl Guard

- + Easy to remove without tools for cleaning
- + Dishwasher-safe for easy cleaning and sanitizing

Soft Start Agitation Technology

- + Gradually delivers electricity to the mixer
- + Minimizes the risk of ingredient splash out

OPERATOR ASSURANCE

Triple Interlock System with MagnaLock Technology

- + Prevents mixer from operating unless the bowl is fully up and locked in place and the bowl guard is secured

HL600 MIXER CAPACITY CHART

Recommended Maximum Capacities – dough capacities based on 70°F water and 12% flour moisture.

Product	Agitators Suitable for Operation	HL600
Capacity of Bowl (Qt. Liquid)		60
Egg Whites	D	2 qt.
Mashed Potatoes	B & C	40 lb.
Whipped Cream	D or C	12 qt.
Cakes		55 lb.
Cookies, Sugar		40 lb.
Dough, Bread or Roll ★ (Lt.-Med.) 60% AR	ED	80 lb. ●
Dough, Heavy Bread 55% AR ★	ED	60 lb. ●
Dough, Thin Pizza 40% AR ★ (max. mix time 5 min.)	ED	40 lb. ●
Dough, Thick Pizza 60% AR ★	ED	70 lb. ●
Dough, Whole Wheat 70% AR	ED	70 lb. ●
Icing, Fondant	B	36 lb.
Icing, Marshmallow	C or I	5 lb.
Pasta, Basic Egg Noodle (max. mix time 5 min.)	ED	30 lb. ●

Note: % AR (% Absorption Ratio) – Water weight divided by flour weight. Capacity depends on moisture content of dough. Above capacities based on 12% flour moisture at 70°F water temperature.

● 1st Speed

■ 2nd Speed

▲ 3rd Speed

★ If high gluten flour is used, reduce above dough batch size by 10%.

2nd speed should never be used on 50% AR or lower products.

Use of ice requires a 10% reduction in batch size.

1 gallon of water weighs 8.33 lbs.

Note: Attachment hub should not be used while mixing.



HL600 LEGACY+ 60-Quart Maximum Heavy-Duty Mixer

SPECIFICATIONS

Motor: 2.7 HP high torque motor.

200-240/50/60/1 – 18.0 Amps

200-240/50/60/3 – 10.0 Amps

380-460/50/60/3 – 6.5 Amps

Electrical: 200-240/50/60/1, 200-240/50/60/3 and 380-460/50/60/3 – UL Listed.

Controls: Magnetic contactor and thermal overload protection. Internally sealed “Start-Stop” and Power Bowl Lift push buttons. Reduced voltage pilot circuit transformer is supplied for 380-460/50/60/3 machines. A 20-minute SmartTimer™ is standard. SmartTimer™ includes:

- **Automatic Time Recall**, which remembers the last time set for each speed.
- **Transmission:** A rated 5.4 HP poly-V belt transfers power from motor to input shaft then geared down to desired reduction with a constant gear mesh. Gears and shafts are heat-treated hardened alloy steel along with anti-friction ball bearings. Circulating oil and grease lubricants furnished to all gears and shafts.

Speeds	Agitator (RPM)	Attachment (RPM)
Stir	36	71
First	71	138
Second	123	241
Third	206	401
Fourth	362	707

Bowl Guard: Heavy-duty stainless steel wire front and solid rear portion. Front portion of guard rotates easily to add ingredients and install or remove agitator. It detaches in seconds for cleaning in dishwasher or sink. Rear portion of guard can be quickly cleaned in position. Guard must be in closed position before mixer will operate. Bowl support interlock provides further protection.

Power Bowl Lift: Powered by an electric motor, the bowl may be raised or lowered by fingertip control through the conveniently located switch. Bowl will remain in position until switch is activated.

Stir-on-Lift Feature: Allows the agitator to run in Stir Speed while the mixer bowl is being raised. Once the bowl is in the raised position, the mixer automatically shifts into the preselected speed.

Finish: Metallic gray hybrid powder coat finish.

Footpads: Neoprene footpads are standard.

Attachment Hub: Comes with front-mounted Hobart standard #12 taper attachment hub for use with Hobart #12 size attachments.



Attachments and Accessories:

The following are available at extra cost:

Attachment / Accessory	Device #
Stainless Steel Bowl	BOWL-HL60
“B” Flat Beater	BBEATER-HL60
“C” Wing Whip	CWHIP-HL60
“D” Wire Whip	DWHIP-HL60
“ED” Dough Hook	EDDOUGH-HL60
“E” Dough Hook	EDOUGH-HL60
“P” Pastry Knife	PPASTRY-HL60
“I” Heavy Duty Wire Whip	IWIRE-HL60
Bowl Splash Cover (lexan)	SPLASH-LEX060
Bowl Scraper	SCRAPER-HL60
Ingredient Chute	CHUTE-HL
Bowl Truck	TRUCK-HL1486
Bowl Extension Ring	EXTEND-SST60G
Deck Plate	DECK-LEG60
9" Vegetable Slicer	VS9
Meat Chopper Attachment	12TIN-C/EPAN
40 Quart Accessories	See HL400 spec sheet

Plugs and Receptacles:

Dependent on local power codes

	Machine Voltages			
	HL600	200-240	200-240	380-460
Service Current Requirement if Plug Connected	200-240/50/60/3/1	230/60/3	460/60/3	
	20 Amp.	20 Amp.	20 Amp.	
Terminal Designation of Plug		3 Pole 4 Wire Grounding	3 Pole 4 Wire Grounding	
NEMA Plug Configuration		L15-20P	L16-20P	
Plug Configuration				
Molded Plug on Cord		No	No	
Plug - Straight/Angle		Straight	Straight	
NEMA Receptacle or Connector Configuration		L15-20R	L16-20R	
Power Cord Included	No	No	No	



HL600 LEGACY+ 60-Quart Maximum Heavy-Duty Mixer

SPECIFICATIONS

Electrical: 200-240/50/60/1, 200-240/50/60/3 and 380-460/50/60/3 – UL Listed.

Weight: Net – 866 lbs.; Shipping – 916 lbs.

Warranty: Unit has full one-year warranty on parts, labor and mileage against manufacturer's defects. Service contracts are available.

DETAILS AND DIMENSIONS

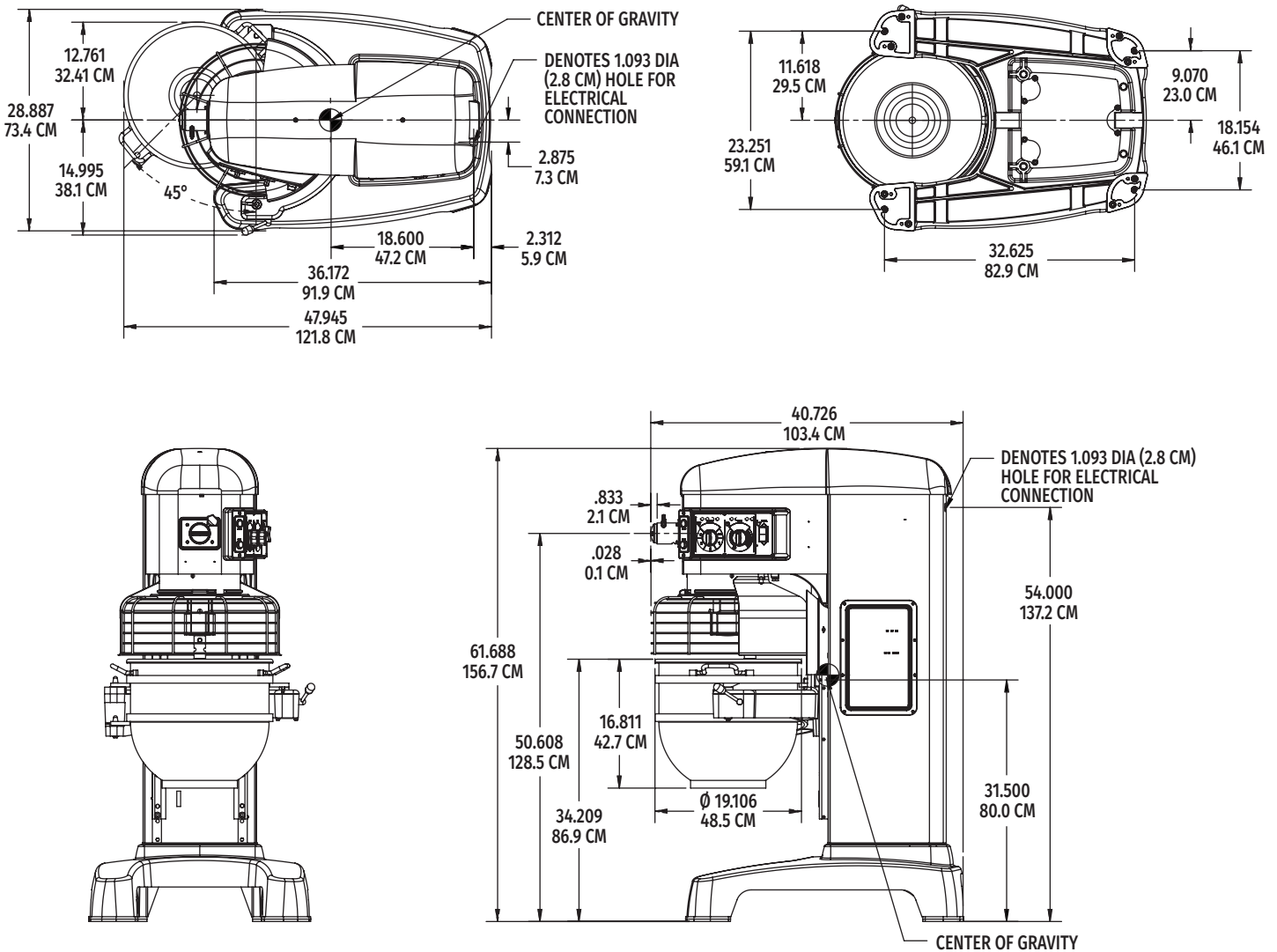

WARNING: Electrical and grounding connections must comply with the applicable portions of the National Electrical Code and/or other codes in force.

NOTE:
Net Weight (Bowl Included): 905 lbs. (411.4 kg)
Domestic Shipping Weight (Bowl Included): 955 lbs. (434.1 kg)
Bowl Weight: 39 lbs. (17.7 kg) - Ref

As continued product improvement is a policy of Hobart, specifications are subject to change without notice.

[CAD and/or Revit Files Available](#)