

HMM20-1STD
Mixer



HMM20-1STD MIXER

MODEL

- HMM20-1STD** 20-quart mixer (19 L)

STANDARD FEATURES

- + Gear transmission
- + Three fixed speeds
- + Beater, whip and dough hook
- + Standard heavy-duty motor
- + ½ H.P. (373 watts) planetary output
- + GearSafe™ technology
- + Digital timer with Last Time Remind
- + Removable bowl guard
- + Large, easy-to-use controls
- + Stainless steel bowl guard
- + Metallic duo-tone styling
- + #12 taper attachment hub

ACCESSORY PACKAGE

- HMM20-1STD Standard accessory package (includes):
 - 20-quart (19 L) stainless steel bowl
 - Flat beater
 - Wire whip
 - Dough hook

SPECIFIER STATEMENT

Specified unit will provide a minimum ½ HP (373 watts) high torque motor. The gear driven transmission will have hardened alloy steel, anti-friction ball bearings. 3-speed controls for maximum performance with agitator RPM speeds of 40,75,137. Digital controls with sealed push buttons and Last Time Remind. Stainless steel bowl, wire whip, flat beater and dough hook provided as well as removable bowl guard.

Approved by _____ Date _____ Approved by _____ Date _____

SOLUTIONS/BENEFITS

STANDARD HEAVY-DUTY PERFORMANCE 

½ HP (375 watts) High Torque Heavy Duty Motor

Gear Transmission

- + Reduced downtime

Three Fixed Speeds

- + For incorporating, blending, mixing ingredients
- + Provides the right speeds for consistent performance

EASE OF USE 

Digital Timer

- + Set minutes and seconds for accurate mixing performance
- + Eliminates overmixing

Last Time Remind

- + Remembers the last time set
- + Great for recipe batch use

Ergonomic Bowl lift with EZ Grip Handle

- + Designed with you in mind

Bayonet Style Agitators

- + Beater, whip and dough hook included

SANITATION & CLEANING 

Stainless Steel Bowl Guard

- + Removes for easy cleaning

OPERATOR ASSURANCE 

GearSafe™ Technology

- + Gear protection for accidental speed changes during operation

Triple Interlock System

- + Bowl-in-place
- + Bowl-up position
- + Bowl guard

HMM20 MIXER CAPACITY CHART

Recommended Maximum Capacities – dough capacities based on 70°F. (21°C) water and 12% flour moisture.

Product	Agitators Suitable for Operation	HMM20
CAPACITY OF BOWL (QUARTS/LITERS LIQUID)		20/19
Egg Whites	whip	1 qt./95
Mashed Potatoes	beater	15 lbs./7 kg
Mayonnaise (quarts/liters of oil)	beater or dough	10 qts./9.5
Meringue (pints/liters of water)	whip	1½ (.71)
Waffle / Hot Cake Batter (qts./L)	beater	8 (7.6)
Whipped Cream (qts./L)	whip	4 (3.8)
Cake, Box or Slab (lbs./kg)	beater	20 (9.1)
Cake, Cup (lbs./kg)	beater	20 (9.1)
Cake, Layer (lbs./kg)	beater	20 (9.1)□
Cake, Pound (lbs./kg)	beater	21 (9.5)□
Cookies, Sugar (lbs./kg)	beater	15 (6.8)
Dough, Bread or Roll (Light-Medium) 60% AR	dough §	25 lbs (11.3 kg)□
Dough Pie (lbs./kg)	beater	18 (8.2)□
Dough, Thin Pizza (lbs./kg) (maximum mix time 5 minutes)	dough §†	9 (4.1)□
Dough, Medium Pizza 50% AR §†	dough	10 lbs. (4.5 kg)□
Dough, Raised 65% AR (lbs./kg)	dough	9 (4.1)*
Dough, Whole Wheat 70% AR	dough	20 lbs. (9.1 kg)
Eggs & Sugar for Sponge Cake	beater	8 lbs. (3.6 kg)
Shortening & Sugar, Creamed	beater	16 lbs. (7.25 kg)
Pasta, Basic Egg Noodle (maximum mix time 5 minutes)	dough	5 lbs. (2.27 kg)

NOTE: % AR (% Absorption Ratio) - Water weight divided by flour weight. Capacity depends on moisture content of dough.

□ 1st Speed

* 2nd Speed

† 3rd Speed

§ If high gluten flour is used, reduce above dough batch size by 10%.

‡ 2nd Speed should never be used on 50% AR or lower products.

USE OF ICE REQUIRES A 10% REDUCTION IN BATCH SIZE.

1 gallon of water weighs 8.33 lbs. (3.78 kg)

NOTE: Attachment hub should not be used while mixing.

SPECIFICATIONS

Motor: ½ HP (373 watts) high torque heavy duty motor
100-120/50/60/1 9.0 Amps

Electrical: 100-120/50/60/1 – ETL Listed.

Controls: Solid state overload protection. Internally sealed “Start-Stop” push buttons. No Volt Release. Standard digital timer. **Last Time Remind**, recalls the time set from last batch operation.

Transmission: Gear-driven. Gears are constant mesh heat-treated hardened alloy steel along with anti-friction ball bearings. Grease lubricants furnished to all gears and shafts.

Speeds:

	Agitator (RPM)
First	40
Second	75
Third	137

Bowl Guard: Stainless steel wire front and solid rear portion. Front portion of guard rotates easily to add ingredients and install or remove agitator. It detaches in seconds for cleaning in dishwasher or sink. Rear portion of guard can be quickly cleaned in position. Guard must be in closed position before mixer will operate.

Bowl Lift: Ergonomic style, hand crank operated, easy to operate.

Finish: Metallic duo-tone gray & black.

Attachment Hub: Comes with front-mounted Hobart standard #12 taper attachment hub for use with Hobart #12 size attachments.

Attachments & Accessories (Available at extra cost):

- BOWL-HMM20 – Stainless steel bowl
- BEATER-HMM20 – Flat beater
- WHIP-HMM20 – Wire whip
- DOUGH-HMM20 – Dough hook
- JDOUGH-HMM20 – “J” Dough hook
- CHUTE-HMM20 – Ingredient chute
- VS9 Vegetable slicer
- Meat chopper attachment

SPECIFICATIONS

Electrical Specifications: 100-120/50/60/1, ETL listed

Weight: 189 lbs. net (86 kg); 204 lbs. (93 kg) domestic shipping.

Warranty: Unit has full one-year warranty on parts, labor and mileage against manufacturer's defects. Service contracts are available.

DETAILS AND DIMENSIONS (US Inches/millimeters)

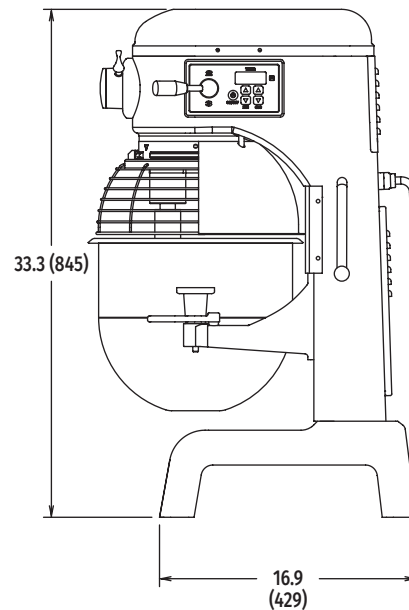
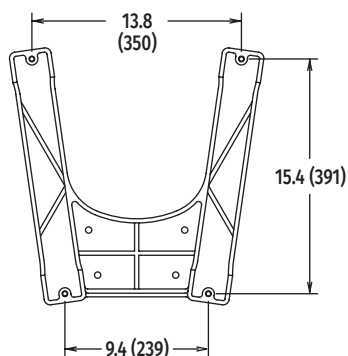
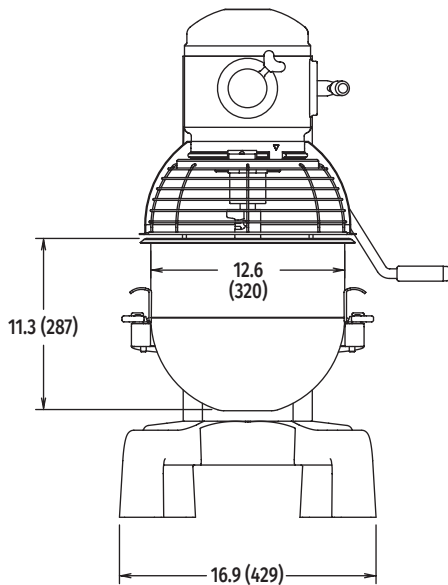
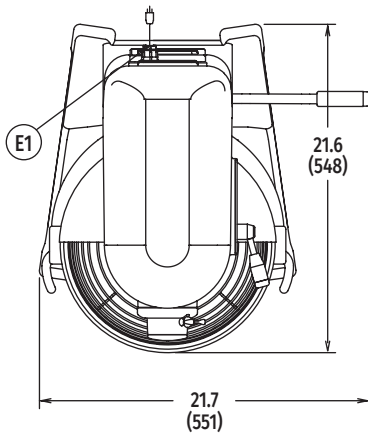

WARNING: Must comply with the applicable portions of the National Electrical Code and/or other local electrical codes.

MACHINE ELECTRICAL SPECS:
100-120/50/60/1 – ETL Listed