

## SLICING

**Berkel****825A-PLUS**  
GRAVITY FEED SLICER

Model 825A-PLUS

**STANDARD FEATURES**

- 1-speed, 1/3 HP, totally enclosed and permanently lubricated knife motor.
- Furnished in 115/60/1, 3.1 amps, AC, ETL listed.
- Finish is stainless steel and sanitary anodized aluminum; unit disassembles quickly without tools for easy cleaning.
- 45° product table with removable meat pusher.
- Nominal 10" (250 mm) diameter; hollow ground, hardened and polished forged chromium-plated carbon steel knife.
- Carriage handles food up to 8 3/4" (222 mm) wide, by 6" (152 mm) high or 7" (178 mm) diameter.
- Precise slice adjustment to a thickness of 9/16" (14 mm).
- Top-mounted, two stone knife sharpener produces a consistently sharp knife edge.
- Permanent, tapered knife ring guard covers non-slicing portion of knife even when the center plate is removed; ring guard design provides more room behind the knife for easy cleaning.
- Positive, moisture protected, on/off switch with power light indicator.
- Attached 6-foot, flexible, 3-wire cord and plug for grounded receptacle (5-15P).

**FEATURES**

Berkel Model 825A-PLUS manual gravity feed slicer features Berkel's hollow ground chromium-plated, carbon steel knife and built-in sharpener. The permanent, tapered guard covers the non-slicing portion of the knife, even when the center plate is removed. The 45° table makes product feed easier, creating more consistent and uniform slices with less waste. The 1/3 HP motor, 10" knife and large product table are ideal for handling oversize meats, cheeses and a variety of other products. The 825A-PLUS is easy to clean and disassembles quickly without tools. The compact space-saving design is ideal for limited kitchen counter space.

**COMPLIES WITH NSF/ANSI STANDARD #8****Berkel**

a division of ITW Food Equipment Group LLC

www.berkequipment.com

P.O. Box 696 ■ Louisville, KY 40201 ■ Toll-free: 1-800-814-2028 ■ Local: 502-778-2791 ■ Quote &amp; Order Fax: 1-800-444-0602

# Berkel

## 825A-PLUS GRAVITY FEED SLICER

### SPECIFICATIONS

**Motor:** 1-speed, 1/3 HP, totally enclosed, permanently lubricated ball bearings, thermally protected.

**Electrical:** Furnished in 115/60/1, 3.1 amps, AC, ETL listed.

**Finish/Construction:** All food contact areas are stainless steel or anodized aluminum including the pusher, gauge plate, product table, center plate, knife ring guard and one-piece base. Slicer disassembles quickly without tools for easy cleaning.

**Knife:** Nominal 10" (250 mm) diameter, hollow ground, hardened and polished forged chromium-plated carbon steel, rotates at 310 rpm.

**Cutting Capacity:** Carriage handles food up to 8<sup>3</sup>/<sub>4</sub>" (222 mm) wide by 6" (152 mm) high or 7" (178 mm) diameter.

**Slice Thickness:** Precision system provides infinite slice adjustment and consistent cuts of hard or soft foods from tissue thin to <sup>9</sup>/<sub>16</sub>" (14 mm).

**Full Gravity Feed:** Full 45° angle feed requires less mechanical pressure. Equipped with removable anodized aluminum pusher to hold product and minimize waste.

**Knife Sharpener:** Top mounted, two stone system for a lasting, razor-sharp edge.

**Knife Ring Guard:** Permanent, tapered guard covers non-slicing portion of knife edge even when the center plate is removed. The ring guard is designed to provide added room behind the knife for easy cleaning.

**On/Off Switch:** Highly reliable, moisture resistant, on/off switch with power light indicator.

**Cord and Plug:** Attached 6-foot, flexible, 3-wire cord and plug for grounded receptacle (5-15P).

**Warranty:** All parts, service and travel coverage for one year, excluding wear items.

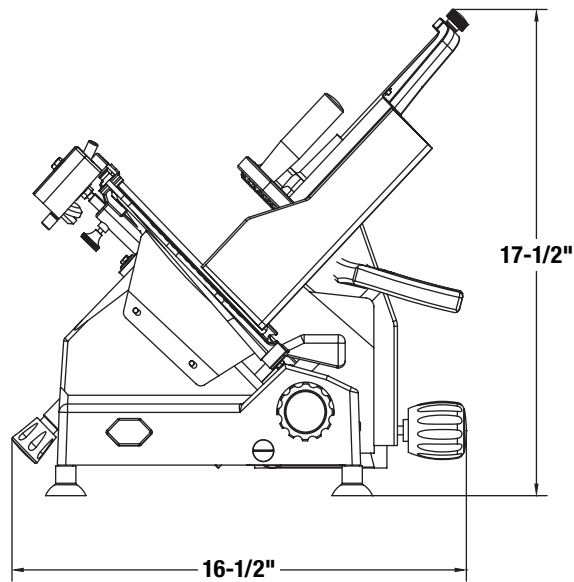
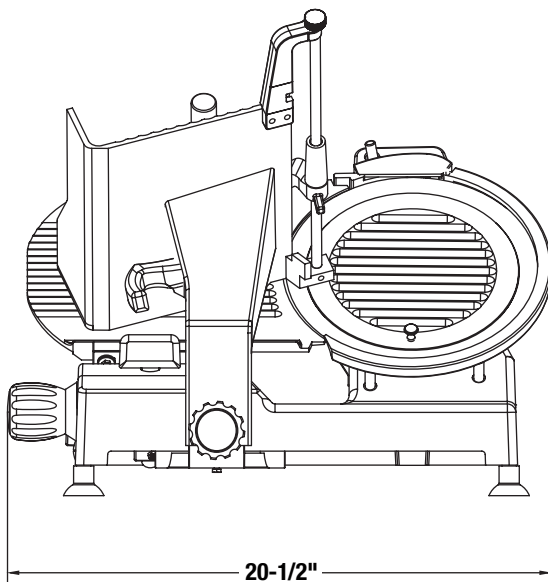

MODEL NUMBER	CUTTING CAPACITY	SLICE THICKNESS	KNIFE DIA.	PRODUCT DIMENSIONS		
				WIDTH	DEPTH	HEIGHT
825A-PLUS	8 <sup>3</sup> / <sub>4</sub> " (222 mm) wide 6" (152 mm) high 7" (178 mm) diameter	to <sup>9</sup> / <sub>16</sub> " (14 mm)	10" (250 mm)	16 <sup>1</sup> / <sub>2</sub> " (419 mm)	20 <sup>1</sup> / <sub>2</sub> " (521 mm)	17 <sup>1</sup> / <sub>2</sub> " (445 mm)

MODEL NUMBER	MOTOR	ELECTRICAL	WEIGHT	BOX DIMENSIONS		
				WIDTH	DEPTH	HEIGHT
825A-PLUS	1-speed 1/3 HP	115/60/1 3.1 amps	Net 37 lbs. (17 kg) Ship 47 lbs. (21 kg)	22 <sup>1</sup> / <sub>2</sub> " (572 mm)	23 <sup>1</sup> / <sub>2</sub> " (597 mm)	23 <sup>1</sup> / <sub>2</sub> " (597 mm)

**Berkel** a division of ITW Food Equipment Group LLC

www.berkequipment.com

P.O. Box 696 ■ Louisville, KY 40201 ■ Toll-free: 1-800-814-2028 ■ Local: 502-778-2791 ■ Quote & Order Fax: 1-800-444-0602